

INITIALS: -  
 JOB NUMBER: 22416  
 DATE: -

MAIN FILE: -  
 DEPT: -  
 DEALER: -

**PRODUCTION APPROVED**

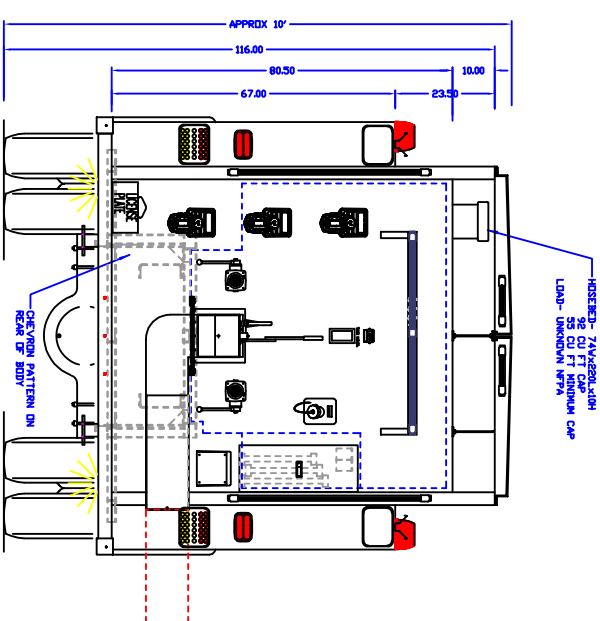
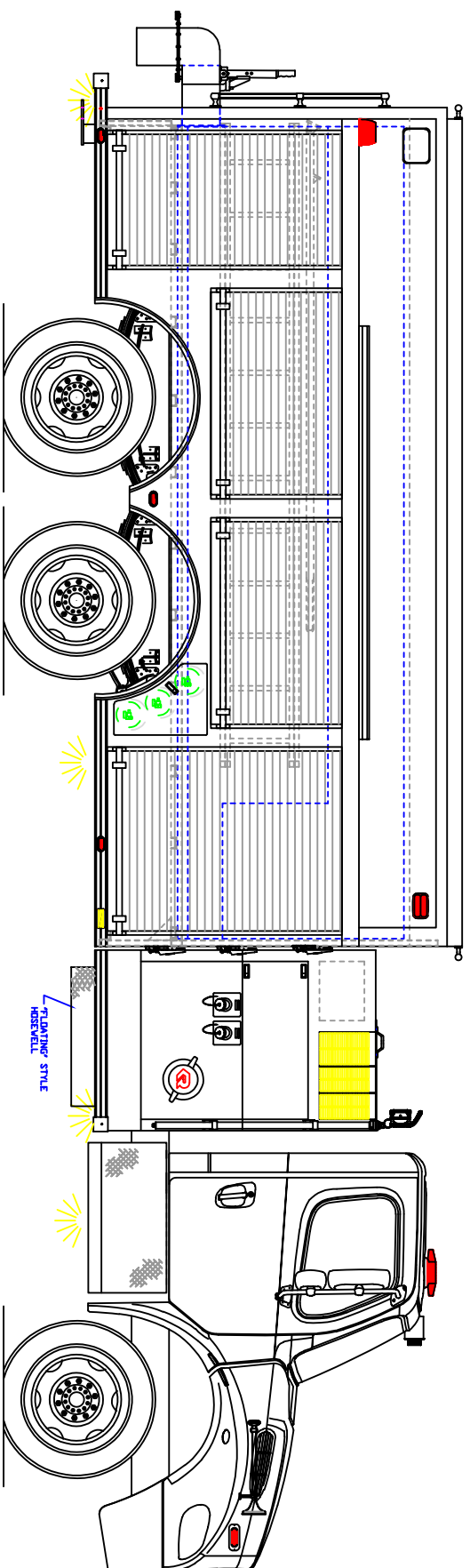
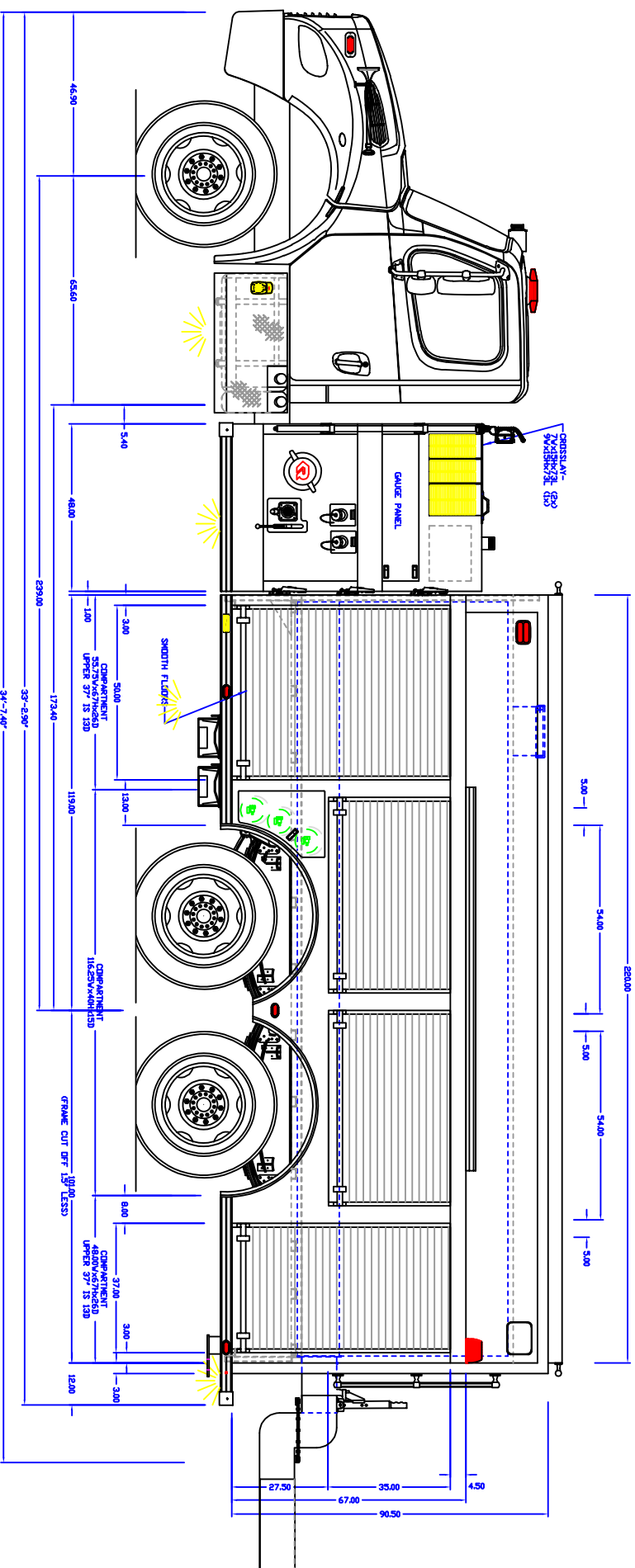
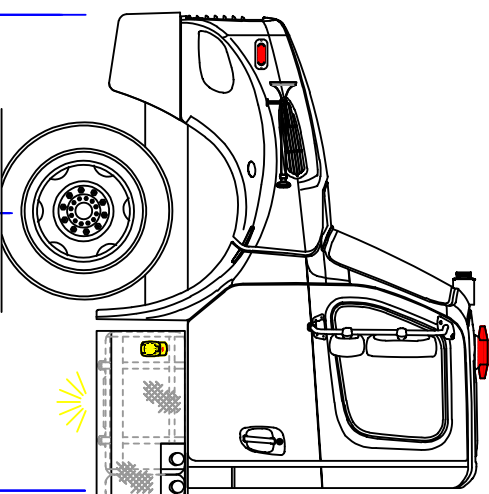
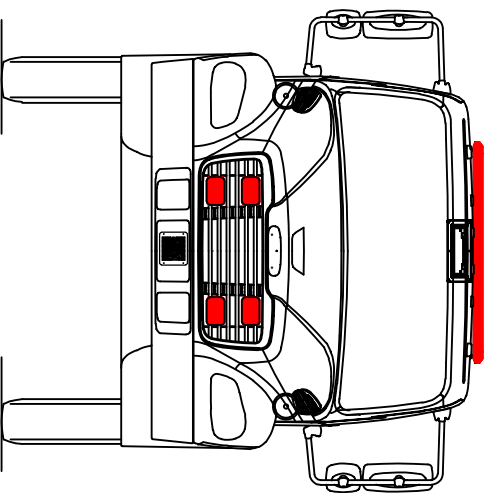

- NOTES:
- OVERALL HEIGHT IS IN LOADED CONDITION. UNLOADED HEIGHTS MAY BE 4" ABOVE HEIGHTS SHOWN.
  - DO NOT SCALE DRAWING.
  - ALL DIMENSIONS ARE APPROXIMATE AND SUBJECT TO ENGINEERING CHANGES.
  - DRAWING MAY OR MAY NOT SHOW ALL ITEMS AS DESCRIBED IN THE WRITTEN DETAIL SPECIFICATIONS.
  - INCLUSION OF AN ITEM ON THE DRAWING DOES NOT CONSTITUTE INCLUSION OF THAT ITEM WITH THE FINAL DELIVERED UNIT.
  - THE EFFECTIVE DOOR OPENINGS WILL BE APPROX. 2" LESS THAN THE NOTED COMPARTMENT OPENING FOR ROLL UP DOORS AND UP TO APPROX. 4" LESS FOR HINGED DOORS

REV 1	KA	DATE 9/27/23	1ST SERIAL NO CHANGE TO VA
REVISED	BVZ	DATE 6/9/23	
DRAWN	BVZ	DATE 5/3/23	

**APPROVED BY:**

CHASSIS:	FREIGHTLINER ZDR
PUMP:	HALE 1250 GPM
TANK:	POLY/3000
PANEL MATL:	STAINLESS STEEL
COMP INTERIOR:	SPATTER PAINTED
MAXIMUM HEIGHT	NONE
MAXIMUM LENGTH	NONE
BODY WIDTH	101"

PROPRIETARY AND CONFIDENTIAL. THE INFORMATION CONTAINED IN THIS DRAWING IS THE SOLE PROPERTY OF ROSENBAUER. ANY REPRODUCTION IN PART OR AS A WHOLE WITHOUT THE WRITTEN PERMISSION OF ROSENBAUER IS PROHIBITED.

**WASHINGTON CO., FL**

